

# Compac Mk5 LiftingRange

ORLIK



- Lift up to 300kg
- Electric Lift Via Ball Screw
- Manual Propulsion
- Stainless Steel 304
- 12V DC Battery
- Internal Battery Charger
- 240v, 110v or 110v USA Charging as required
- Fixed or Pendent Control Buttons
- 3 Types Of Wheel Options Swivel, Fixed or Rocking Pallet Wheels
- Built To Suit Your Needs
  - Height to suit
  - Leg length to suit
  - Leg Width to suit
- Counterbalance Weights if needed
- IP65 Kit Optional
- Full Bespoke Design Service Available
- Handling Goods including Drums, Wheels, Tooling, Reels, Barrels etc.....

Reel Handling Vertical to Horizontal Via the Core



Drum and Reel Handling Vertical to Horizontal Via the External Diameter

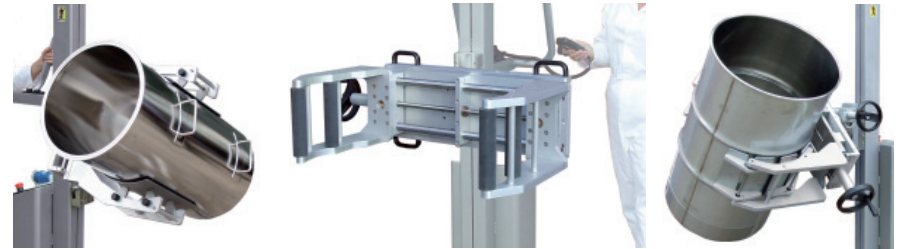

Reel Handling in a Fixed Orientation by Core or External Diameter



Drum Handling Vertical to Horizontal Via the External Diameter



# Pallet and Wheel Options

## Open Sided Pallets

Castors 50mm dia or 100mm dia

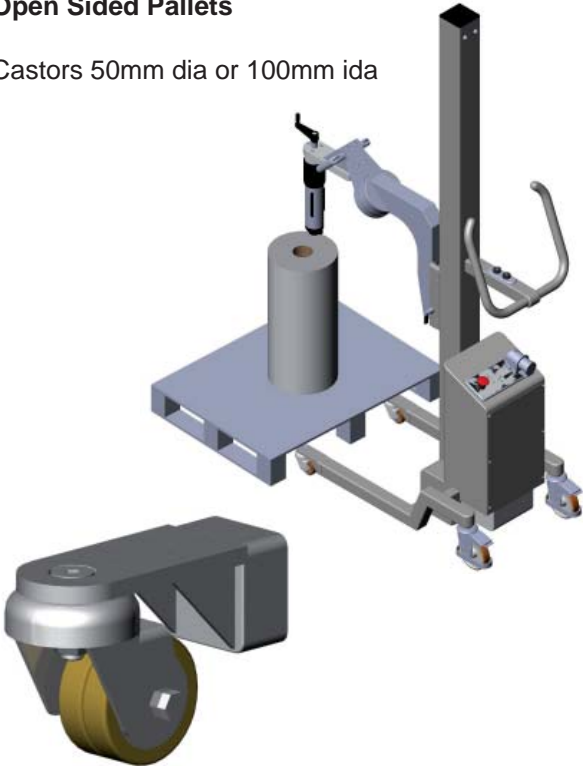

## Open Sided Pallets

Fixed Pallet Wheels 85mm dia

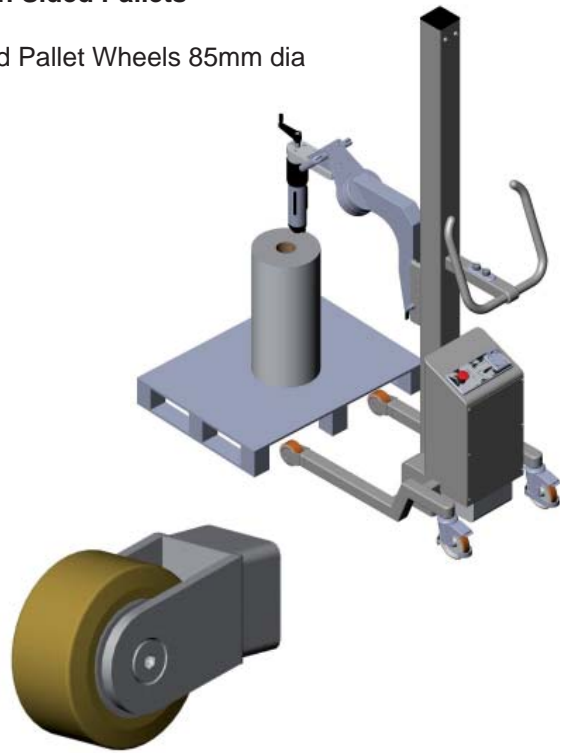

## Closed Pallets

Rocking Pallet Wheels 85mm dia

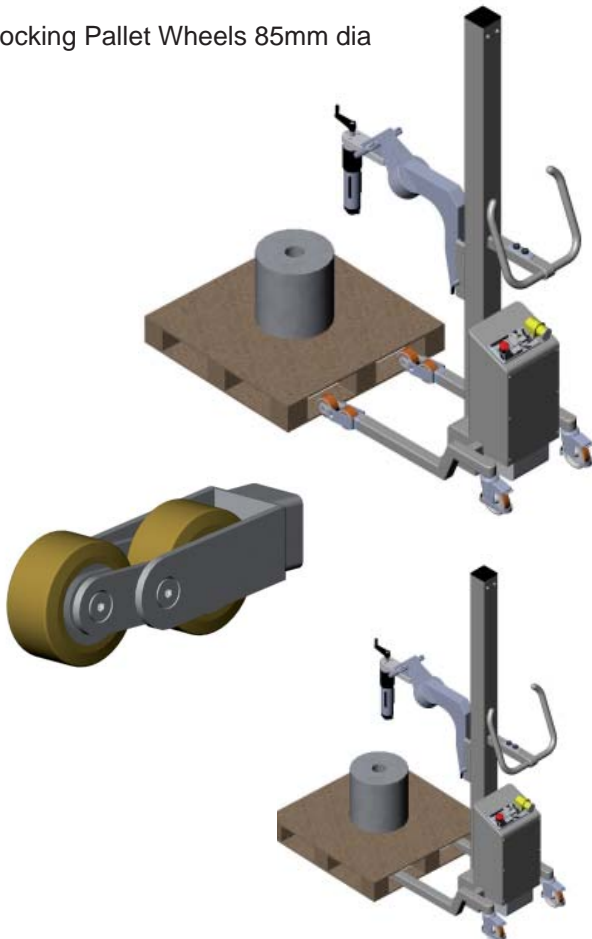

## Sub or Slave Pallet Creates Open Sided Pallets

Castors 50mm or 100mm dia  
Fixed Pallet Wheels 85mm dia

