



BG Pack Vetta Vertical Form Fill & Seal

BG Vetta

BG Vetta: Vertical Easy Technologies

"All in one" per confezioni marketing oriented: BG PACK progetta il carro di saldatura girevole a 90° ed una serie di particolari tecnici in dotazione alla macchina che permettono a VETTA di realizzare una vasta gamma di confezioni diverse ed innovative con cambi formato in tempi brevissimi.

User Friendly: 2 motori in asse brushless controllati da PC con pannello touch screen a colori, software realizzato in ambiente Windows NT per facilitare al massimo le fasi di programmazione.

Sanificabilità: pochi minuti per pulire completamente la macchina, anche nei punti più difficili, tutto a portata di mano, facilmente accessibile ed estraibile.

"All in one" for marketing oriented packages: BG PACK designs the 90° revolving sealing carriage and a series of technical parts supplied with the machines that allow VETTA to produce a large range of various and innovative packages and with rapid format changes.

User Friendly: twin-axled brushless motors controlled by PC with a colour touch screen panel, and software development based on Windows NT in order to give the utmost simplicity in each programming stage.

Cleaning: in just a few minutes the machine can be completely cleaned, even in the most difficult areas, all of which are within reach, easily accessible and extractable.

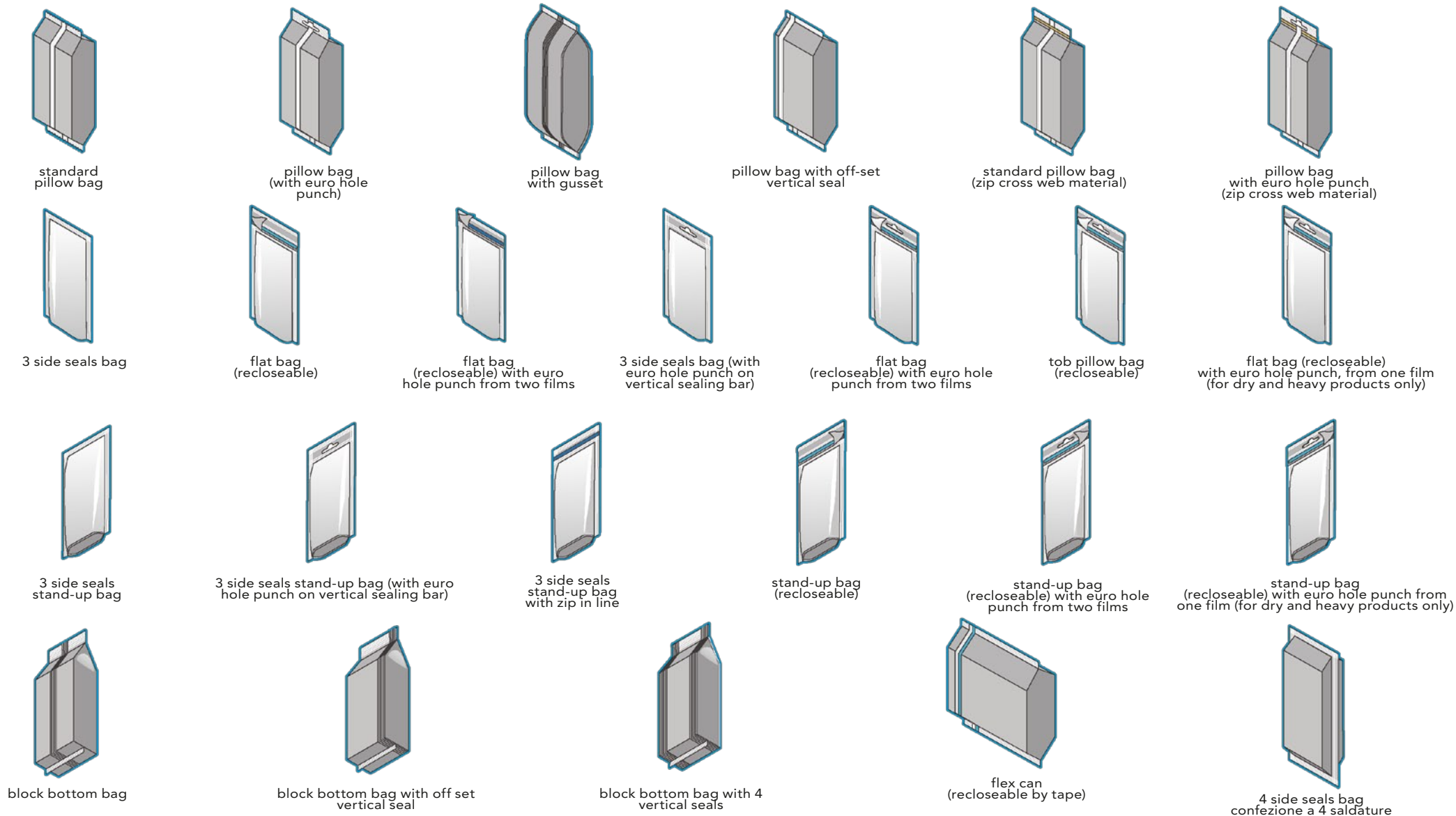

BG Vetta: the "All in One Machine"



BG Vetta



Controllo e Velocità

Massima costanza ed affidabilità sono le caratteristiche che consentono a VETTA di raggiungere elevatissimi standard di produzione: confezioni innovative con estetica perfetta ed assoluta tenuta delle saldature.

Control and Speed

The utmost constancy and reliability are the characteristics that allow VETTA to reach the highest standards of production: innovative packaging with a perfect appearance and complete seal resistance.



The "Open & Reclose" Packages

Confezioni con patella richiudibile e banda adesiva o con zip. "Open & Reclose" è un sistema che consente la richiudibilità delle confezioni.

E' adatto per tutti i prodotti alimentari, il cui consumo avviene normalmente in due-tre fasi.

La richiudibilità della confezione assicura il buon mantenimento e la freschezza del prodotto.

La praticità di apertura offre vantaggi di marketing consistenti al consumatore.

Packaging with a resealable tab and with an adhesive strip or zip. "Open & Reclose" is a system that allows the packaging to be resealed.

It is suitable for all types of food products that would normally be consumed in two or three stages.

The resealability of the packaging guarantees freshness and good preservation of the product, and its easy opening ensures notable marketing advantages for the consumer.

Marketing Oriented Packaging

- Permettono il confezionamento in atmosfera protettiva (MAP), per prolungare in piena sicurezza il periodo di conservazione del prodotto.
- Attraenti, senza grinze e imperfezioni.
- Richiudibili.
- Ecologiche.
- Totalmente Stampabili.
- Modified Atmosphere Packaging (MAP), for food preservation, is allowed.
- Perfect appearance.
- Reclosable.
- Ecological.
- Entirely printable.



Esempi di prodotti confezionabili.
Examples of packageable products.

BG Vetta



User Friendly

Macchina gestita da PLC tramite pannello touch screen a colori.

Machine controlled by PLC with colour screen touch panel.



Pannello di controllo Touch Screen.
Touch Screen control panel interface.

Dosing Systems

Dosatore a coclea

Ideale per dosare polveri e affini. Una coclea (vite senza fine) specifica per ogni prodotto, dosa con precisione direttamente all'interno del tubo formatore della confezionatrice. Il sistema è facilmente smontabile per l'igienizzazione.

Auger dosing unit

It consists of a loading hopper, inside which a worm screw (auger) turns. A specific amount of product is dosed according to the number of revolutions and the screw pitch. This is ideal for very fine products.

Dosatore volumetrico

Fino a sei tazze telescopiche. Ideale per dosare prodotti granulari fini. Regolabile manualmente o automaticamente, facilmente igienizzabile. Dispone di vari optional in funzione delle esigenze specifiche.

Volumetric dosing unit

Up to six telescopic cups. Ideal for dosing fine granular products. Can be adjusted manually or automatically, easy to clean thoroughly. A number of options are available depending on specific requirements.

Bilancia lineare a piani vibranti

Per prodotti granulari di medie e grandi dimensioni composta da una serie di piani vibranti i quali hanno la funzione di spingere i prodotti verso la cella di pesatura. Appena raggiunto il peso programmato i piani vibranti si bloccano e la cella di pesatura scarica il contenuto all'interno del tubo conformatore del materiale d'incarto della confezionatrice.

Linear scales with vibrating surfaces

They are used for granular products with medium to large dimensions and includes a set of vibrating surfaces, which push the product towards the weighing cell. As soon as the programmed weight has been reached, the vibrating surfaces come to an immediate halt and the weighing cell empties its contents into the wrapping material forming collar on the packaging machine.

Bilancia Multiteste

Sistema di pesatura a testate multiple a combinazione. Velocità, precisione, affidabilità e igiene. Vari modelli disponibili in funzione delle esigenze specifiche. Quando è richiesta alta produzione con massima precisione di pesata.

Multihead Weigher

Multiple combination weighing system. Fast, accurate, reliable and hygienic. Available in various models to suit specific requirements. The ideal weighing solution for achieving high production levels with maximum accuracy.

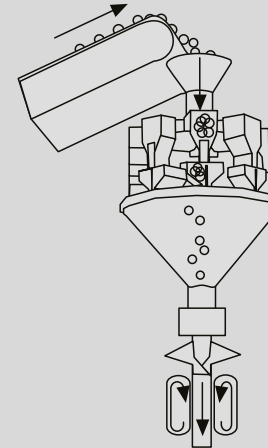
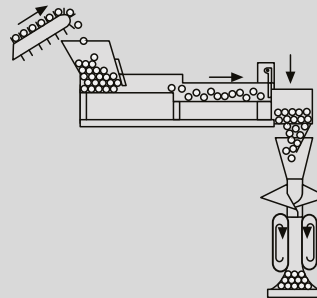
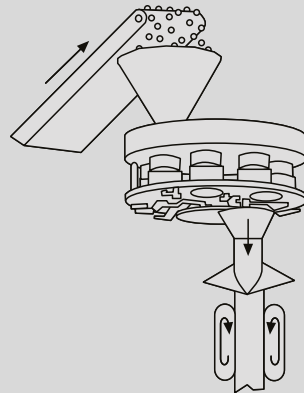
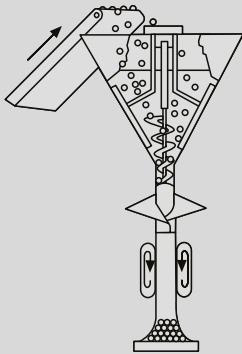

- Farina
- Cacao
- Latte in polvere
- Polveri chimiche
- ecc...
- Flour
- Cocoa
- Powdered milk
- Chemical powders
- etc....

- Sale
- Zucchero
- Riso
- Legumi
- Caffè
- ecc...

- Salt
- Sugar
- Rice
- Pulses
- Coffee
- etc....

- Pistacchi
- Arachidi
- Pastine
- Surgelati
- Caramelle
- Formaggio grattugiato
- ecc...

- Pistachios
- Peanuts
- Cakes
- Frozen foods
- Sweets
- Grated cheese
- etc....

- Pane
- Biscotti
- Snacks
- Pasta
- Chips
- Patatine surgelate
- ecc...

- Bread
- Biscuits
- Snacks
- Pasta
- Chips
- Frozen chips
- Small pieces
- etc....



Esempi di prodotti confezionabili.
Examples of packageable products.

Technical Data



Particolare di due tubi conformatori.
Detail of two forming tubes.

VETTA 2038

Larghezza confezione (mm): 200 - Bobina film 430
Bag width (mm): 200 - Web film 430

Lunghezza confezione (mm): 380 (fino a 500 con doppio traino)
Bag length (mm): 380 (up to 500 with double pull)

Velocità massima (conf./min): 120 (240 versione twin)
Max speed (bags/min): 120 (240 version twin)

Altezza da terra (mm): 1600 (senza tunnel)
Height from the floor (mm): 1600 (without tunnel)

Versione: destra, sinistra e twin (2 machines)
Version: right, left and twin (2 machines)

VETTA 3348

330 - Bobina film 690
330 - Web film 690

480 (fino a 600 con doppio traino)
480 (up to 600 with double pull)

100
100

1900 (senza tunnel)
1900 (without tunnel)

destra, sinistra
right, left

VETTA 4048

400 - Bobina film 840
400 - Web film 840

480 (fino a 600 con doppio traino)
480 (up to 600 with double pull)

80
80

1900 (senza tunnel)
1900 (without tunnel)

destra, sinistra
right, left

BG Pack si riserva il diritto di modificare i dati tecnici senza preavviso. / BG Pack reserve the right to make modifications without prior notice.

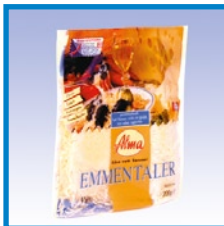

block bottom bag with
4 vertical seals



block bottom bag
with 4 vertical seals



flat bag
(recloseable)
with euro hole
punch from
two films

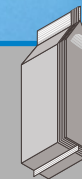

block bottom bag
with off set vertical
seal



3 side seals
stand-up bag

PFM Group: un Network di Soluzioni nel Packaging

PFM Packaging Machinery è un gruppo industriale costituito da dieci aziende: la società madre, **PFM Packaging Machinery**, lavora in collaborazione con **PFM UK Ltd**, con **PFM Corporation North America** e con la tedesca **PFM Germany**. Vi sono poi **BG Pack SPA**, con sede a Bergamo, specializzata nella produzione di confezionatrici speciali per confezioni richiudibili; **MBP**, azienda con sede a Mantova, specializzata nella produzione di pesatrici multiteste e confezionatrici verticali, a completamento della gamma di prodotti offerti da **PFM**. L'ultima in ordine di acquisizione è **SPS Italiana Pack Systems**, ritornata nelle mani dei fondatori dopo vari cambi di proprietà. Questa azienda di Novara produce confezionatrici automatiche per prodotti da forno e biscotti. Nel 2006 è stata fondata l'azienda **PFmeccanica** che costituisce un nuovo centro di produzione per componenti meccanici. Nel novembre del 2007 viene fondata **PFM Russia**, la nuova base commerciale e logistica per i mercati dell'Est-Europa. Nel 2010 nasce **PFM Iberica**. Un altissimo livello di specializzazione delle varie unità produttive, la perfetta integrazione tra i diversi reparti tecnici, che rimangono tuttavia indipendenti, l'organizzazione secondo Vision 2000 dei settori marketing e assistenza sono alcuni dei fattori che hanno portato il Gruppo ad ottenere risultati eccellenti: 300 dipendenti e un fatturato di 71 milioni di Euro nel 2010. Il **Gruppo PFM** soddisfa tutte le esigenze del packaging flessibile in tutte le industrie alimentari e non alimentari ed il suo nome è un punto di riferimento per il mercato mondiale.

PFM Group: a Network of Packaging Solutions

PFM Packaging Machinery is an industrial group made up of 10 companies: the Italian parent company, **PFM Packaging Machinery**, which works alongside the **UK PFM LTD**, North American **PFM Corporation**, and German **PFM Germany** companies. **BG Pack SPA**, which is based in Bergamo, specialising in the manufacture of special packaging machines for recloseable packs. **MBP**, based in Mantua, specialise in the production of multi-head weighers and vertical packaging machines thereby completing the range offered by **PFM**. Last in order of acquisition is **SPS Italiana Pack Systems**, which has come back into the hands of those who founded the company after exchanging ownership a number of times: this Company from Novara manufacture automatic handling and packaging machines for baked goods and biscuits, chocolate bars and wafers. In 2006 **PFmeccanica** was founded to form a new production centre for mechanical components. In November 2007 **PFM Russia** was founded, the new commercial and logistic base for the Eastern European markets. In 2010 **PFM Iberica** was founded. An extremely high level of specialisation of the individual manufacturing units, perfect integration between the individual technical departments, which also remain independent, Vision 2000 organisation of marketing and after-sales areas, are a few of the factors which have helped the Group achieve major results: 300 employees and a turnover of 71 million Euros in 2010. The **PFM Group** meets all the requirements of flexible packaging in all the food and non food industries and has made a major name for itself on the world market.



PFM GROUP
the packaging experience

www.pfm.it



PFM S.p.A.
PACKAGING MACHINERY
ITALIAN HEADQUARTERS

Via Pasubio, 49
36036 TORREBELVICINO
VICENZA
ITALY

Tel: (+39) 0445. 66.22.00
Fax: (+39) 0445. 570.175

www.pfm.it
pfm@pfm.it



PFM
PACKAGING MACHINERY LTD
UNITED KINGDOM

PFM House, 2
Pilgrim Way, Stanningley
LEEDS - LS28 6LU
UNITED KINGDOM

Tel: +44 (0) 113. 23.93.401
Fax: +44 (0) 113. 23.93.402

www.pfmuk.com
pfm@pfmuk.com



PFM
PACKAGING MACHINERY CORP.
NORTH AMERICA

1271, Ringwell Ave.
NEWMARKET
ONTARIO
CANADA L3Y 7V1

Tel: (+1) 905. 836.6709
Fax: (+1) 905. 836.7763

www.pfmusa.com
info@pfmusa.com



PFM
Verpackungsmaschinen GmbH

Gewerbestraße, 14
D-21279 HOLLENSTEDT
GERMANY

Tel: (+49) 4165. 221.921
Fax: (+49) 4165. 221.922

www.pfmgermany.de
info@pfmgermany.de



OOO "PFM Russia"
PACKAGING MACHINERY
PFM PACKAGING GROUP

Ul. Garibaldi, 36
117418 MOSCOW
RUSSIA

Tel: (+7) 495. 33.11.911
Fax: (+7) 495. 71.83.766

www.pfmrossia.ru
moscowpfm@yandex.ru



PFM IBERICA
PACKAGING MACHINERY S.A.
PFM PACKAGING GROUP

Calle Ponent n. 78 - Nave C-6 -
Pol. Ind. Can Mascaró
08756 LA PALMA DE CERVELLO
(Barcelona) - ESPAÑA

Tel: (+34) 93. 47.00.910
Fax: (+34) 93. 48.09.018

www.pfm.es
pfmiberica@pfm.es



BG PACK S.p.A.
PACKAGING MACHINERY
PFM PACKAGING GROUP

Via C. A. Dalla Chiesa, 13
24048 TREVIOLO (BG)
ITALY

Tel: (+39) 035. 20.31.22
Fax: (+39) 035. 20.31.25

www.bgpack.it
bgpack@bgpack.it



MBP S.r.l.
MULTIHEAD WEIGHERS
PFM PACKAGING GROUP

Via Toscanini, 48/B
46043 CASTIGLIONE
DELLE STIVIERE (MN) ITALY

Tel: (+39) 0376. 638.479
Fax: (+39) 0376. 670.727

www.mbp.it
info@mbp.it



SPS
ITALIANA PACK SYSTEMS S.p.A.
PFM PACKAGING GROUP

Via S.Isidoro, 6
28010 BOGOGNO (NO)
ITALY

Tel: (+39) 0322. 861.100
Fax: (+39) 0322. 861.122

www.spspack.com
info@spspack.com



PFmeccanica
COMPONENTS PRODUCTION CENTRE
PFM PACKAGING GROUP

Via Casa Celeste, 7
36014 SANTORSO (VI)
ITALY

Tel: (+39) 0445. 570.134
Fax: (+39) 0445. 570.175

www.pfm.it
pfm@pfm.it