

**Packaging Machinery**



## **PFM Milk Packaging**

CONFEZIONAMENTO DEL LATTE VACCINO E BUFALINO  
COW AND BUFFALO MILK PACKAGING

# PFM Milk Packaging

## CONFEZIONAMENTO DEL LATTE VACCINO E BUFALINO

### Prodotti:

Latte vaccino e bufalino concentrato e non.

### Confezionamento:

- Pillow bag a 3 saldature fino a 6 litri con PFM ZENITH.
- Pillow bag a 3 saldature fino a 12 litri con PFM PV-320.

## COW AND BUFFALO MILK PACKAGING

### Products:

Cow and buffalo milk used in the manufacture of mozzarella.

### Packaging:

- 3-seal pillow bag up to 6 litres on PFM ZENITH.
- 3-seal pillow bag up to 12 litres on PFM PV-320.



# PFM Cow and Buffalo Milk Packaging.

## Produzione:

- Fino a 12 confezioni da 5 litri/min. in funzione del materiale d'incarto con PFM ZENITH EW.
- Fino a 8 confezioni da 10 litri/min. in funzione del materiale d'incarto con PFM PV-320.

### Materiale d'incarto:

Accoppiato PA/15 e PE/100 speciale per basse temperature.

### Composizione della Linea:

- Macchina confezionatrice modello PFM ZENITH INOX EW o, in alternativa modello PFM PV-320.
- Dosatore speciale per latte.
- Gruppo di sterilizzazione film a raggi UV.
- Pompa a vuoto per aspirazione aria in eccesso all'interno della confezione.
- Sistema di sostegno della confezione con supporto mobile.
- Nastro in uscita INOX.

## Vantaggi:

- Sistema completamente automatico direttamente collegato alla linea di trattamento del latte.
- Il sistema produce confezioni assolutamente igieniche rispetto al tradizionale confezionamento manuale in bidoni.
- Facilità di stoccaggio offerta dal confezionamento flow pack.
- Rapidità di congelamento e scongelamento.

## Production rate:

- PFM ZENITH EW - Up to 12 five-litre packs/min. depending on type of packaging material used.
- PFM PV-320 - Up to 8 ten-litre packs/min. depending on type of packaging material used.

### Packaging material:

Special PA/15 and PE/100 bonded material, for use at low temperatures (freezable).

### Line comprises:

- PFM ZENITH INOX EW or alternatively, model PFM PV-320 packaging machine.
- Special dosing device for milk.
- UV ray unit for sterilising film.
- Vacuum pump for removing excess air from inside packs.
- Mobile bag support system.
- STAINLESS STEEL discharge belt.

## Advantages:

- Fully automatic system directly connected to the milk processing line.
- Improved pack hygiene compared to traditional packaging in cans.
- Finished packs are more compact and easier to store than traditional cans.
- Laminate wrapping materials enables fast freezing and defrosting.

# PFM PV-320 PN INOX



## PFM PV-320 PN INOX Caratteristiche Tecniche

Macchina confezionatrice tipo form-fill-seal che realizza confezioni a 3 saldature tipo pillow pack da bobina di materiale d'incarto a foglia piana.

- Larghezza fascia bobina fino a 800 mm.
- Struttura monolitica interamente realizzata in acciaio AISI 304
- Ha le stesse dotazioni ed accessori della ZENITH INOX EW ma realizza formati maggiori.

## PFM PV-320 PN INOX Technical Features

Form-fill-seal type packaging machine which produces pillow packs with 3 seals from a flat reel of foil wrapping material.

- Max. wrapping size 800 mm.
- Single block structure made entirely of AISI 304 steel.
- Comes complete with the same features and accessories as the ZENITH INOX EW with the capacity for larger pack sizes.

# PFM ZENITH INOX EW



## PFM ZENITH INOX EW Caratteristiche Tecniche

**Macchina confezionatrice tipo form-fill-seal che realizza confezioni a 3 saldature ermetiche partendo da bobina di materiale plastico termosaldante.**

- Larghezza max. fascia bobina 700 mm.
- Struttura della macchina progettata contro infiltrazioni di agenti corrosivi e costruita in acciaio inox 304. Tutte le parti a contatto con il prodotto sono in AISI 316.
- Controllo elettronico della temperatura con margine di errore di +/- 2 °C.
- Controllo di tutte le funzioni tramite PLC con tastiera programmabile.
- Tubo formatore con sistema di sgancio rapido per cambio formato in tempi brevissimi.

## PFM ZENITH INOX EW Technical Features

**Form-fill-seal type packaging machine which produces 3-seal hermetic packs starting from a reel of heat-sealable wrapping material.**

- Max film width 700 mm.
- Machine constructed in 304 stainless steel.
- All product contact parts constructed from AISI 316.
- Electronic temperature control with +/- 2 °C accuracy.
- All functions controlled by PLC using a programmable keyboard.
- Forming tube with rapid coupling system for extremely quick format changeovers.

# PFM Dosing Device



## DOSATORE

Lo speciale dosatore per latte PFM è adatto anche al dosaggio di latte concentrato, interamente costruito in acciaio AISI 316, è completo di vasca di accumulo da 30 litri, speciali iniettori antischiuma, è predisposto per l'allacciamento all'impianto di lavaggio CIP centralizzato.

## DOSING DEVICE

The special PFM milk dosing device is also suitable for dosing concentrated milk; it is constructed entirely of AISI 316 steel and comes complete with 30-litre accumulation tank, special foam-prevention injectors and is also designed to be coupled with a centralised CIP washing system.

## Machines Layout

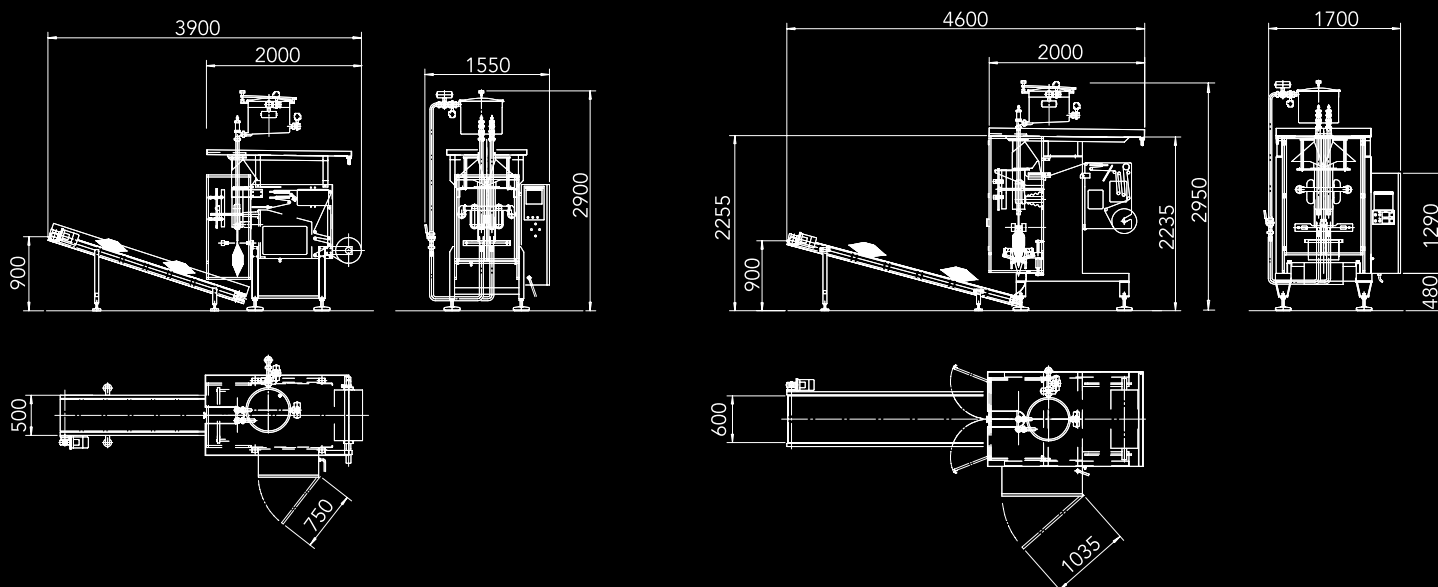

### PFM ZENITH INOX EW

Larghezza confezione / Pack width: fino a / up to 330 mm  
 Lunghezza confezione / Pack length: fino a / up to 450 mm  
 Fascia bobina / Reel width: 700 mm  
 Diametro bobina / Reel diameter: 350 mm  
 Consumo elettrico / Electrical consumption: 6 kw  
 Consumo pneumatico / Air consumption: 300 NI/min  
 Peso / Weight: 950 kg

### PFM PV-320 PN INOX

Larghezza confezione / Pack width: fino a / up to 390 mm  
 Lunghezza confezione / Pack length: fino a / up to 500 mm  
 Fascia bobina / Reel width: 800 mm  
 Diametro bobina / Reel diameter: 350 mm  
 Consumo elettrico / Electrical consumption: 6 kw  
 Consumo pneumatico / Air consumption: 300 NI/min  
 Peso / Weight: 1100 kg



[www.pfmgroup.com](http://www.pfmgroup.com)



**PFM S.p.A.**  
Packaging Machinery  
ITALIAN HEADQUARTERS

Via Pasubio, 49  
36036  
Torrebelvicino  
VICENZA  
ITALY

Ph: (+39) 0445. 66.22.00  
Fx: (+39) 0445. 570.175

[www.pfm.it](http://www.pfm.it)  
[pfm@pfm.it](mailto:pfm@pfm.it)



**PFM**  
Packaging Machinery LTD  
UNITED KINGDOM

PFM House  
2 Pilgrim Way  
Stanningley  
LEEDS - LS28 6LU  
UNITED KINGDOM

Ph: +44 (0) 113. 23.93.401  
Fx: +44 (0) 113. 23.93.402

[www.pfmuk.com](http://www.pfmuk.com)  
[pfm@pfmuk.com](mailto:pfm@pfmuk.com)



**PFM**  
Packaging Machinery  
Corporation

NORTH AMERICA  
1271 Ringwell Drive  
Newmarket - L3Y 8T9  
ONTARIO  
CANADA

Ph: 905. 836.6709  
Fx: 905. 836.7763

[www.pfmnorthamerica.com](http://www.pfmnorthamerica.com)  
[info@pfmnorthamerica.com](mailto:info@pfmnorthamerica.com)



**PFM NA**  
US Division Inc.

15200 Transistor Lane  
Huntington Beach  
92649  
CALIFORNIA  
USA

Ph: 714. 799.2867  
Fx: 714. 799.2897

[www.pfmusa.com](http://www.pfmusa.com)  
[info@pfmusa.com](mailto:info@pfmusa.com)



**PFM**  
Verpackungsmaschinen GmbH

Gewerbestraße, 14  
D-21279  
HOLLENSTEDT  
GERMANY

Ph: (+49) 4165. 221.921  
Fx: (+49) 4165. 221.922

[www.pfmgermany.de](http://www.pfmgermany.de)  
[info@pfmgermany.de](mailto:info@pfmgermany.de)



**OOO "PFM Russia"**  
Packaging Machinery  
PFM PACKAGING GROUP

Ul. Profsojuznaya, 3  
117036  
MOSCOW  
RUSSIA

Ph: (+7) 499. 608.03.78  
Fx: (+7) 499. 608.03.78

[www.pfmussia.ru](http://www.pfmussia.ru)  
[moscowpfm@yandex.ru](mailto:moscowpfm@yandex.ru)



**PFM IBERICA**  
Packaging Machinery S.A.  
PFM PACKAGING GROUP

Calle Ponent n. 78 - Nave C-6  
Pol. Ind. Can Mascaró  
08756 La Palma de Cervello  
BARCELONA  
ESPAÑA

Ph: (+34) 93. 47.00.910  
Fx: (+34) 93. 48.09.018

[www.pfm.es](http://www.pfm.es)  
[pfmiberica@pfm.es](mailto:pfmiberica@pfm.es)



**PFM CHINA**  
Packaging Machinery  
(Shanghai) Co., Ltd.

58, Changliu Rd  
Zendai Cube Building  
Room 303 B  
Shanghai 200135  
P.R.CHINA

Ph: (+86 ) 21.6162.0512  
Fx: (+86 ) 21.5838.5233

[www.pfm.it](http://www.pfm.it)  
[pfmchina@pfm.it](mailto:pfmchina@pfm.it)



**BG PACK S.p.A.**  
Packaging Machinery  
PFM PACKAGING GROUP

Via C. A. Dalla Chiesa, 13  
24048  
Treviolo  
BERGAMO  
ITALY

Ph: (+39) 035. 20.31.22  
Fx: (+39) 035. 20.31.25

[www.bgpack.it](http://www.bgpack.it)  
[bgpack@bgpack.it](mailto:bgpack@bgpack.it)



**MBP S.r.l.**  
MULTIHEAD WEIGHERS  
PFM PACKAGING GROUP

Via Toscanini, 48/B  
46043  
Castiglione delle Stiviere  
MANTOVA  
ITALY

Ph: (+39) 0376. 638.479  
Fx: (+39) 0376. 670.727

[www.mbp.it](http://www.mbp.it)  
[info@mbp.it](mailto:info@mbp.it)



**SPS**  
ITALIANA PACK SYSTEMS S.p.A.  
PFM PACKAGING GROUP

Via S.Isidoro, 6  
28010  
Bogogno  
NOVARA  
ITALY

Ph: (+39) 0322. 861.100  
Fx: (+39) 0322. 861.122

[www.spspack.com](http://www.spspack.com)  
[info@spspack.com](mailto:info@spspack.com)



**Pfmecanica**  
COMPONENTS PRODUCTION CENTRE  
PFM PACKAGING GROUP

Via Casa Celeste, 7  
36014  
Santorso  
VICENZA  
ITALY

Ph: (+39) 0445. 570.134  
Fx: (+39) 0445. 570.175

[www.pfm.it](http://www.pfm.it)  
[pfm@pfm.it](mailto:pfm@pfm.it)